



Easysnap

THE ONE HAND OPENING UNIT DOSE

STAR

P L U S

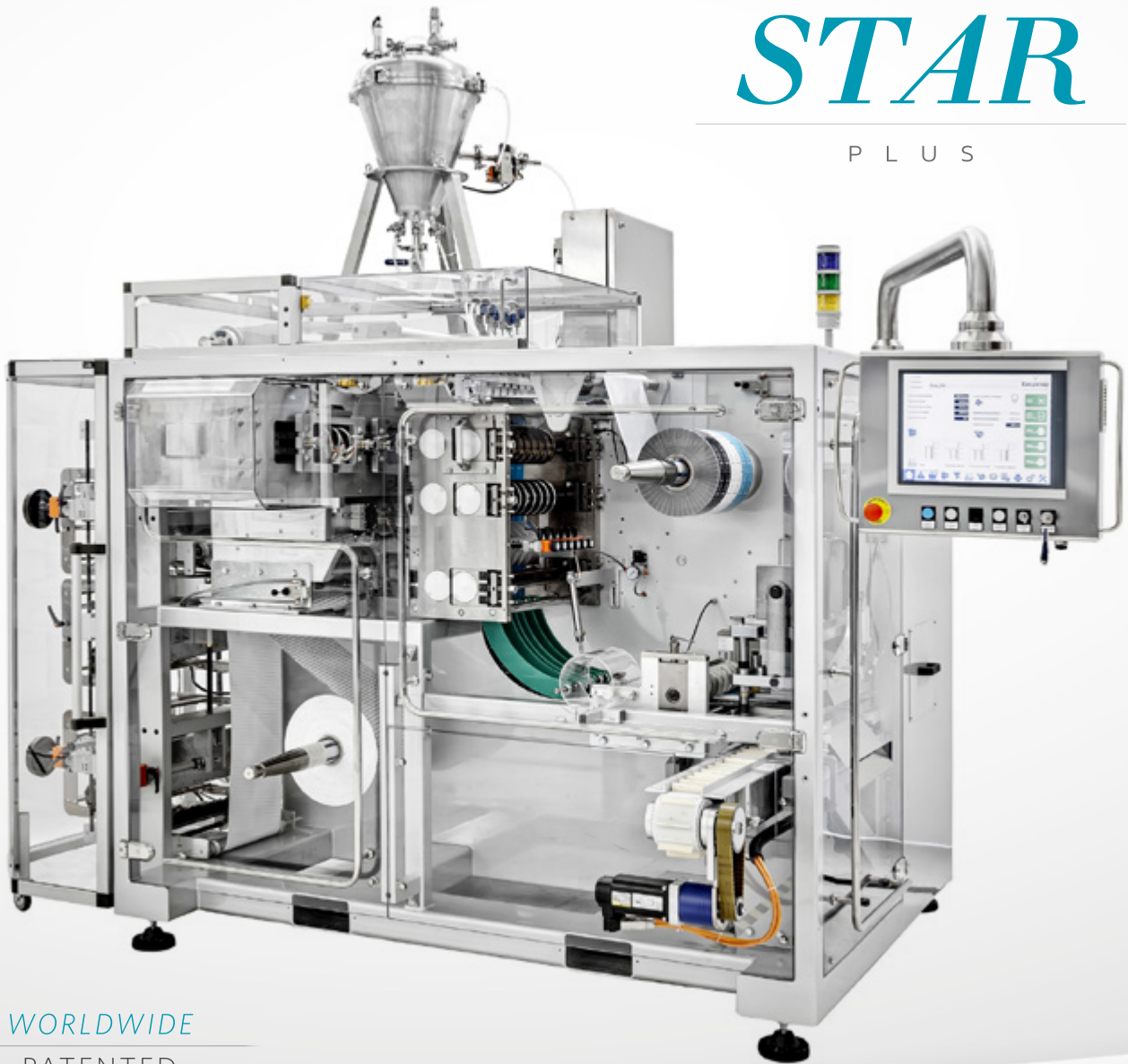

WORLDWIDE
PATENTED

THE NEW AND INNOVATIVE SOLUTION FOR SINGLE PORTION PACKS



BEND



or FOLD



SNAP



SQUEEZE



The only worldwide one hand opening and dispensing unit dose (pouch) for liquid products.



- It can replace any conventional portion pack container for liquid products in the food, cosmetic, personal care, chemical and medical device industry.
- The only worldwide single-dose unit with a one hand opening and dispensing system and high standard usability, best suitable for use of elderly or disabled persons.
- From now on available a bio-based version with a percentage of bio-based materials up to 92% for unit dose, according to ASTM D6400 standards)

how to use
SNAP & SQUEEZE



WITH ONE HAND

- Secure opening upon sachet folding over 90° degrees, therefore NO accidental opening.
- High standard usability
- Accessible to persons with disabilities
- No mess, no spill, hygienically clean opening.
- No waste: due to sachet structure, 99% of product is dispensed.
- No air inside and 100% barrier properties for high product integrity and shelf life.
- Innovative packaging design for new marketing strategies
- No product contamination since it cannot be re-closed or re-used like a bottle or tube.
- Complies with latest European regulations with obliges one time use not refillable container to be used.
- High resolution printing surface available (front and back) of pouch.
- Material costs equal to the 4-side seal tear top sachet, therefore very competitive.
- Very low transportation costs due to the compact/flat volume.
- Can be filled with any liquid or semi-liquid products
- If an Easysnap pouch is placed near any conventional container, it has 95% chance of being selected by the consumer.
- Worldwide patented pouch. No counterfeiting possibility if brand products are in an "Easysnap".

STANDARD SIZE AND VOLUMES





STAR

P L U S

MACHINE GROUPS

- New product bucket out-feed conveyor compatible with any secondary automation (cartoning - blistering - weighing machine).
- New open-source software compatible with ERP software (SAP, AS400, Oracle, Diapason, etc...).
- New machine protection structure.
- Solid innovative anti-vibration frame structure.
- All product contact parts in stainless steel AISI 316 certified for food/cosmetic/medical device applications.
- Modem for PLC tele-assistance.
- Filling/Dosing unit for up to 3% accuracy.
- Patented 6 lane variable micrometric pre-set cut group.
- Heat transfer printing system for full size pouch print.
- Whole machine operations driven by 7 multiple Bosch brushless motors.
- Various change sets available for up to 30 ml fill.

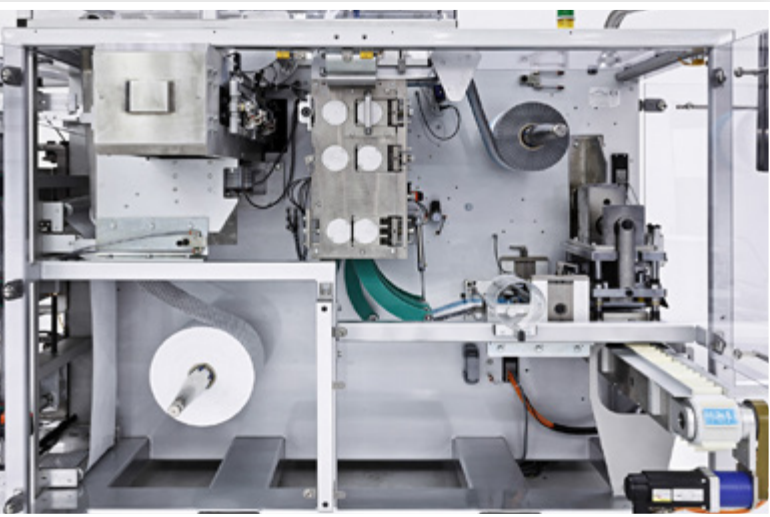

High speed performance:
up to 240 sachets/min.





MACHINE FEATURES

- ✓ The only one hand opening/dispensing worldwide patented pouch machine.
- ✓ High speed performance: up to 240 sachets/min.
- ✓ 45 min. time for a complete change set operation.
- ✓ Top and bottom film automatically driven towards cutting/filling/printing and towards final pouch die-cutting in only 3 meter machine footprint.
- ✓ Machine can print full size bottom side pouch through its heat transfer printing unit.
- ✓ Any laminated film can be handled for proper product shelf-life.
- ✓ One operator can supervise up to 2 machines.
- ✓ Very low maintenance cost because of very few mechanical non-standard parts.

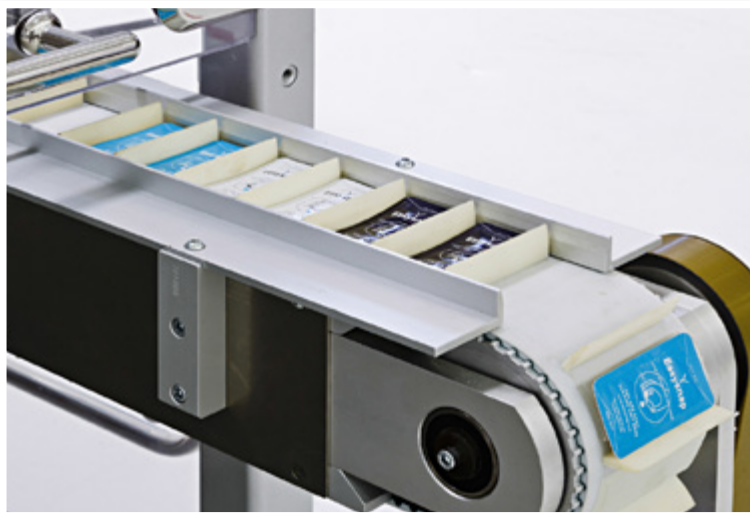

Designed to meet any portion pack filling needs for food, cosmetics and medical device packaging.



Easysnap technology is designed and certified for food, cosmetic, medical, pharma and chemical device industries.



DISPLAY



New HMI layout for the simply management of all the technical aspects and the settings of the machine, with easy access to catalogs and video tutorial



New open-source software & UX navigation widescreen 15" Touchscreen, compatible with ERP software.

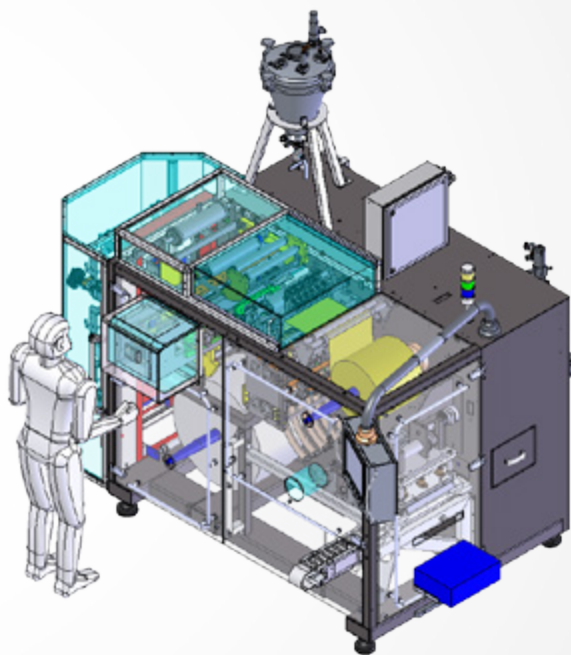
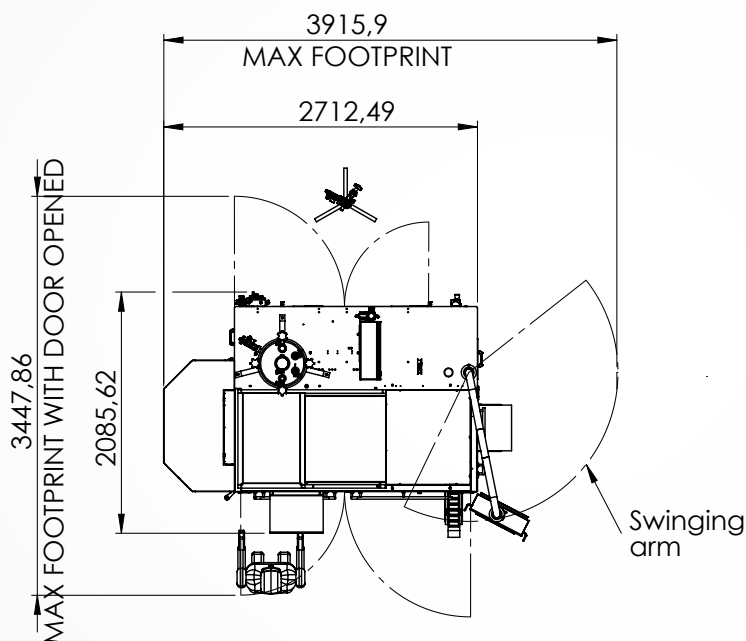
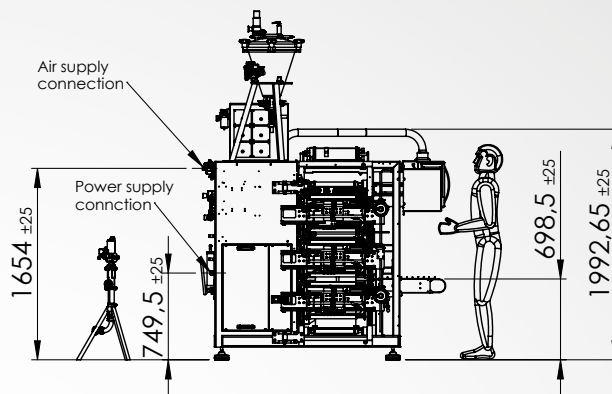
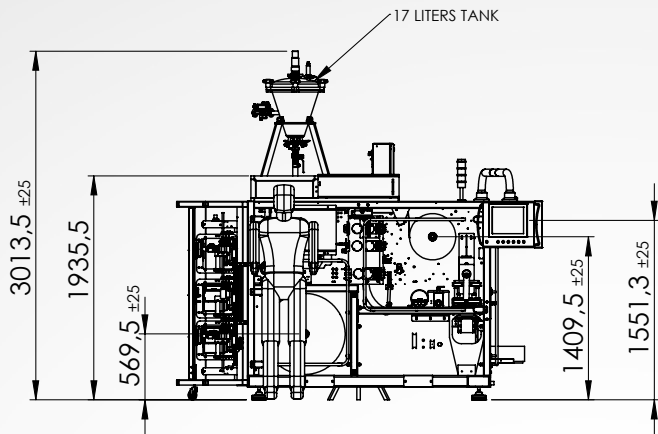

STAR
PLUS

TECHNICAL DATA SHEET

| | |
|--|---|
| Easysnap machine model: | STAR Plus |
| Production capacity: | Up to 240 sachets/minute (on 6 lanes) |
| Installed power: | 28 kWh (peak) |
| Air consumption: | 600 NI/min |
| Changeover size time: | 45 minutes |
| Machine weight: | 2.800 kg |
| Max film reels dimensions and weights: | Rigid film on left reel diam.700mm. (max 100kg) Flexible film on right reel diam. 400mm. (max 100kg) |
| Machine color: | RAL 9007 other RAL colors upon request |
| Electricals: | 400 V - 3 phase + N + Ground - 50 Hz / IP55 |
| HMI: | B&R 15" touch screen |
| Patent Numbers: | WO 2008/038074 - PCT IB2007001285; WO 2009/040629 - PCT IB20080002474; EP2076451B1; EP 2205505B; EP2628691B1; BO 2012A0000080; TO2014A000007; BO2014A000249; BO2014A000230; BO2014A000231; BO2014A000232. |

CONTACT US!



EASYSNAP GROUP
Via Davia 9/D, 40017
San Giovanni in Persiceto
Bologna - Italy

Tel. (+39) 051 68 10 804
Fax (+39) 051 95 00 91
info@easysnap.com
www.easysnap.com

facebook.com/easysnap
twitter.com/easysnap_sachet
vimeo.com/easysnap
linkedin.com/company/easysnap